

# DEMAG AC 95

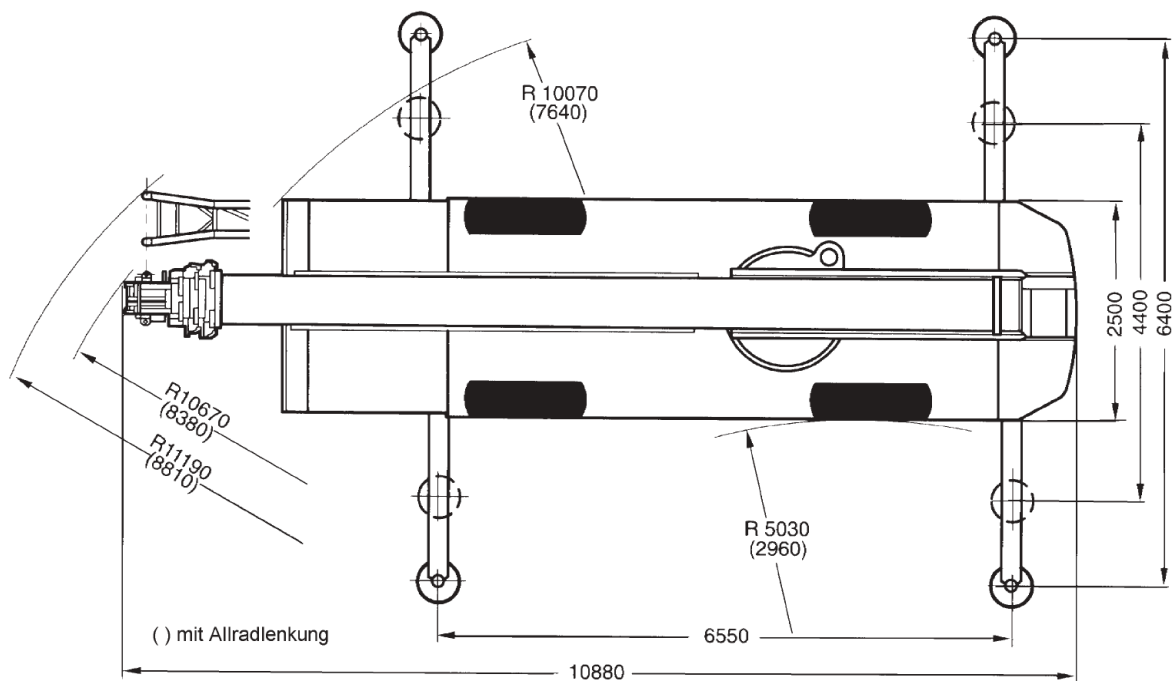

# DEMAG AC 95

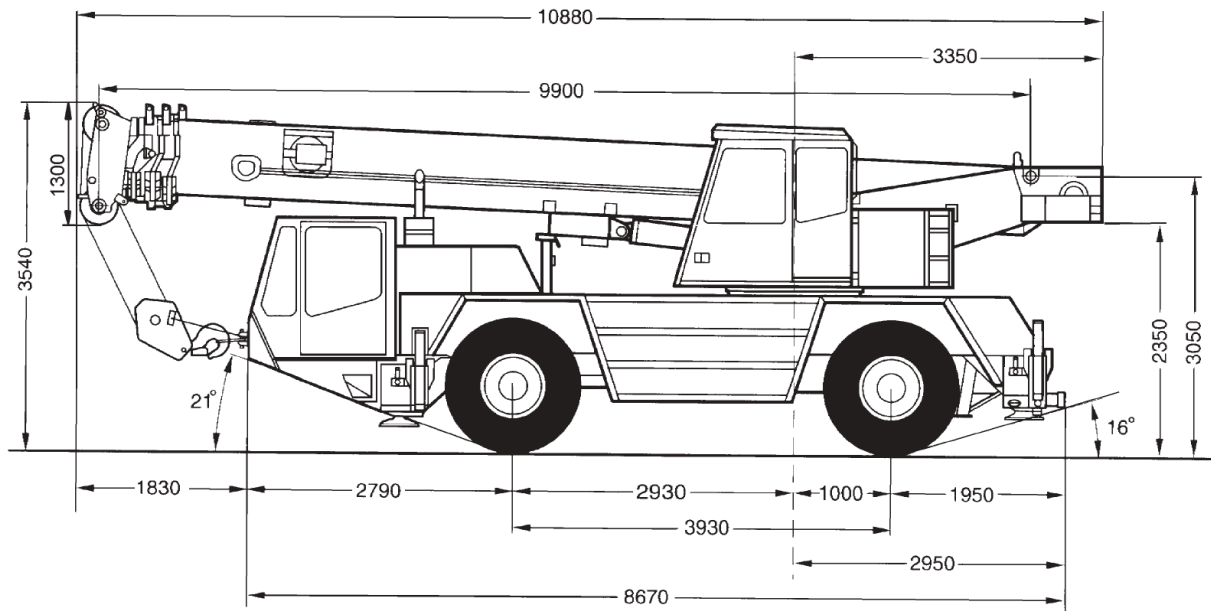
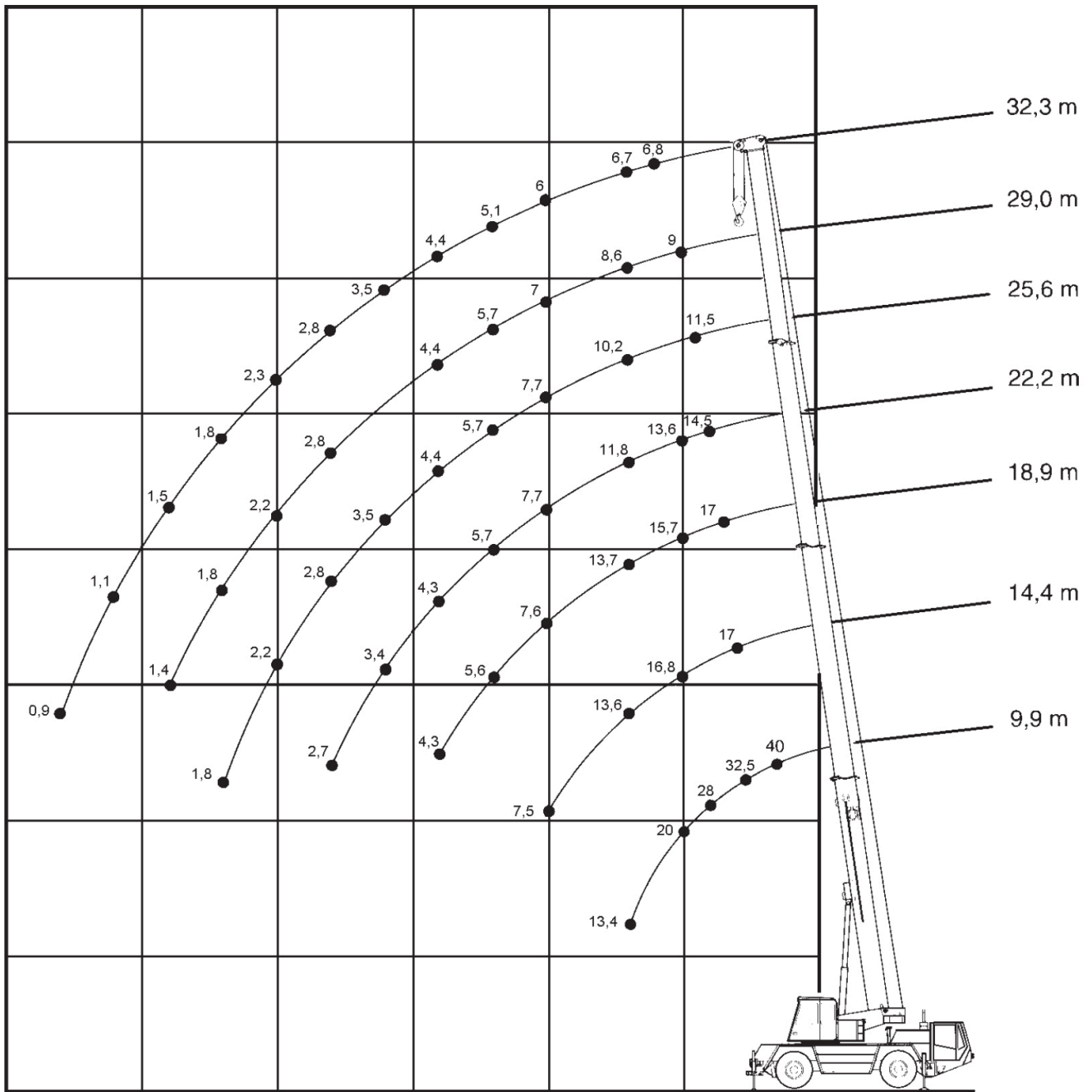

# DEMAG AC 95



9,9-32,3m



5,2t



6,55x6,4m



360°



75%

m	9,9*	9,9	14,4	18,9	22,2	25,6	29	32,3	m
3	40	32	17						3
3,5	32,5	28,9	17	17					3,5
4	28	26,1	17	16,6	14,5				4
4,5	24	22,7	17	16,2	14,1	11,5			4,5
5	20	20	16,8	15,7	13,6	11,3	9		5
6	16,1	16,1	15,7	15,2	12,8	10,9	8,8	6,8	6
7	13,4	13,4	13,6	13,7	11,8	10,2	8,6	6,7	7
8			10,9	11	10,8	9,4	8,2	6,6	8
9			8,9	9	9,1	8,7	7,6	6,4	9
10			7,5	7,6	7,7	7,7	7	6	10
12				5,6	5,7	5,7	5,7	5,1	12
14				4,3	4,3	4,4	4,4	4,4	14
16					3,4	3,5	3,5	3,5	16
18					2,7	2,8	2,8	2,8	18
20						2,2	2,2	2,3	20
22						1,8	1,8	1,8	22
24							1,4	1,5	24
26								1,1	26
28								0,9	28

\* over rear

# DEMAG AC 95

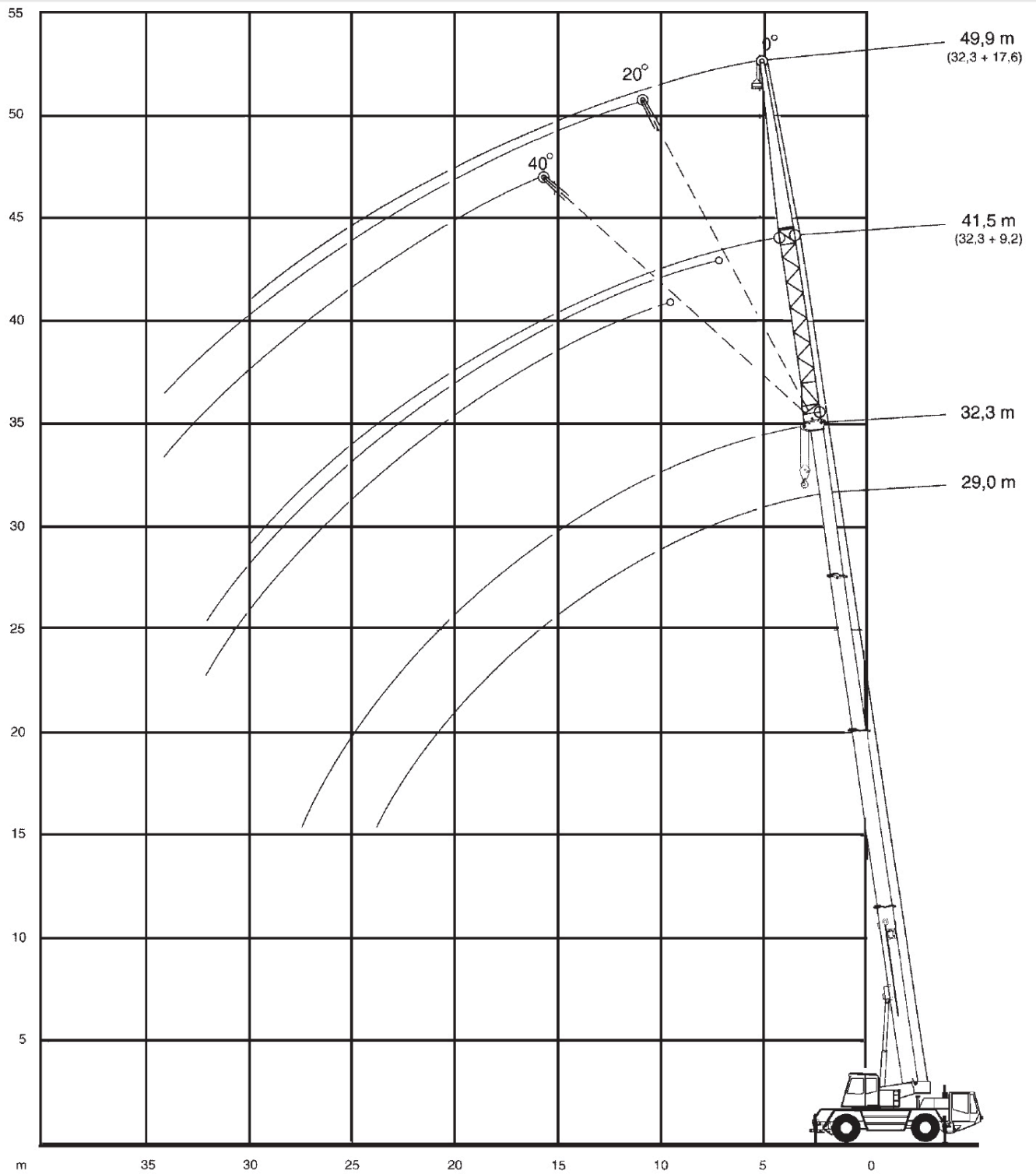

# DEMAG AC 95



29-32,3m



9,2m



5,2t



6,55x6,4m



360°



DIN

75%

m	29			32,3			m
	0°	20°	40°	0°	20°	40°	
7	4						7
8	4			3			8
9	4			3			9
10	4	3,6		3			10
12	3,9	3,6	3,3	3	3		12
14	3,8	3,6	3,3	2,9	3	3	14
16	3,5	3,3	3,1	2,8	2,9	2,9	16
18	2,9	3	2,9	2,7	2,7	2,6	18
20	2,4	2,6	2,7	2,3	2,4	2,4	20
22	1,9	2,1	2,2	1,9	2,1	2,2	22
24	1,5	1,7	1,8	1,5	1,7	1,8	24
26	1,2	1,3	1,4	1,1	1,3	1,4	26
28	0,9	1	1,1	0,9	1	1,1	28
30	0,7	0,8	0,8	0,7	0,7	0,8	30
32		0,6			0,6	0,6	32



29-32,3m



17,6m



5,2t



6,55x6,4m



360°



DIN

75%

m	29			32,3			m
	0°	20°	40°	0°	20°	40°	
9	1,7						9
10	1,7			1			10
12	1,7			1			12
14	1,7			1			14
16	1,7	1,7		1	1		16
18	1,7	1,7		1	1		18
20	1,7	1,6	1,5	1	1	1	20
22	1,7	1,5	1,4	1	1	1	22
24	1,6	1,5	1,4	1	1	1	24
26	1,3	1,4	1,4	1	1	1	26
28	1	1,3	1,3	1	1	1	28
30	0,8	1,1	1,3	0,7	1	1	30
32	0,6	0,8	1		0,8	1	32
34		0,6	0,7		0,6	0,7	34