



HANGCHA



# R Series

10.0 T  
Diesel



ZHEJIANG HANGCHA ENGINEERING MACHINERY CO.,LTD.

# DIMENSIONS

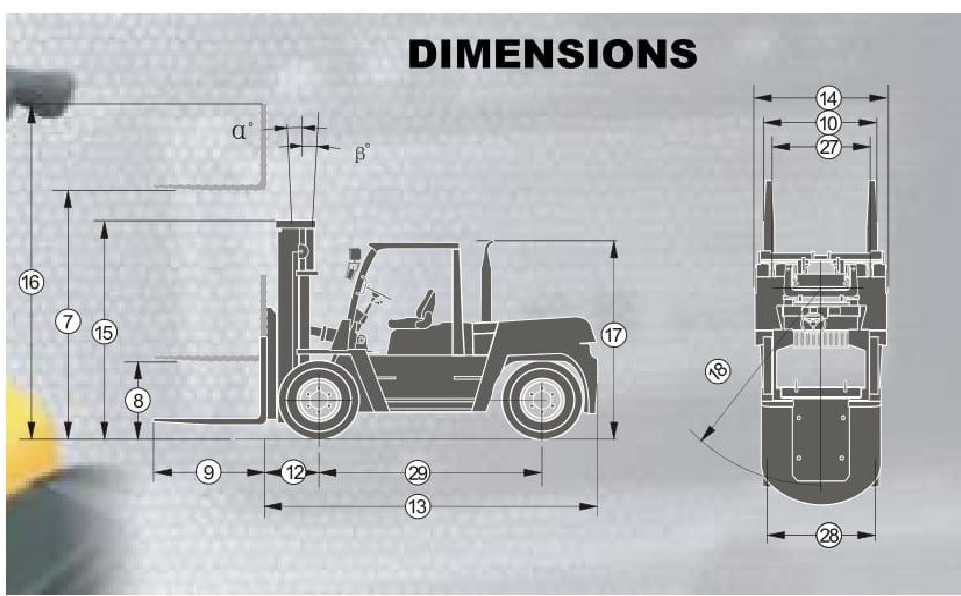

## R series 10.0t forklift mast specification:

Type	Model	Mast fork height	Overall height		Free lift	Tilt range		Capacity
			Lowered	Extended With backrest	With backrest	FWD	RWD	Load capacity at 600 mm
						mm	mm	mm
		3600	3150	5155	200	6	12	10000

## R series 10.0t forklift specification

General				CPCD100				
				RG16	RG17	RG25	RW14	RW28
1	Manufacture							
2	Basic model			CPCD100				
3	Type			Diesel				
4	Power type			10000				
5	Rated capacity	kg		600				
6	Load center	mm		3000				
7	Lift height	mm		200				
8	Free lift height	mm		1500×160×80				
9	Fork size	L×W×T		440 / 1800				
10	Fork spread(outside)	Min. / Max.		6 / 12				
11	Mast tilt range	F / R		730				
12	Fork overhang(Wheel center to fork face)	mm		4235				
13	Overall dimensions	Length to face of fork		2165				
		Overall width		2850				
		Mast lowered height		4510				
		Mast extended height		2540				
		Overhead guard height		4050				
14	Turning radius(outside)	mm		3600				
15	Min.right angle aisle width	mm		6480				
16	Min.right angle stacking aisle width (Add load length and clearance)	mm		0 ~26				
21	Speed	Travel	Km/h	320				
		Lifting(Full load)	mm/sec	326				
22	Max.gradeability(Full load)	%		20				
23	Self weight	kg		13000				
25	Tyres	Front	mm	9.00 - 20 - 14PR				
		Rear	mm	9.00 - 20 - 14PR				
26	Tread	Front / Rear		1600 / 1700				
27	Wheelbase	mm		2800				
28	Ground clearance	mm		250				
29	Battery	Voltage / Capacity(5HR)		24 / 90				
31	Engine	Model		6BG1QP				
		Manufacture		ISUZU				
		Rated output / r.p.m.		84.6 / 2200				
		Rated torque / r.p.m.		411/1400~1600				
		No.of cylinder		6				
		Bore×Stroke		105×125				
		Emission STD.		6494				
		Displacement		cc				
		Fuel tank capacity		L				
		120		CHINA				
40	Transmissions	Manufacture		Powershift				
		Type		2 / 2				
41	Stage	FWD/RVS		19.5				
42	Operating pressure	For attachments		MPa				

## LOAD CHART

